

1. A proton moves in a constant electric field \vec{E} from point A to point B. The magnitude of the electric field is $6.4 \times 10^4 \text{ N/C}$; and it is directed as shown in the drawing, the direction opposite to the motion of the proton. If the distance from point A to point B is 0.50 m, what is the change in the proton's electric potential energy, $EPE_A - EPE_B$?

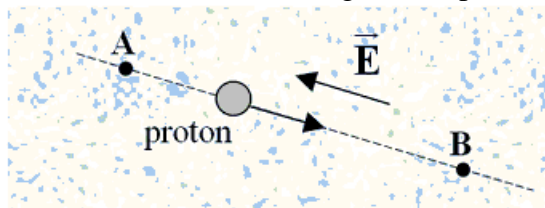

- A) $-2.4 \times 10^{-15} \text{ J}$
 B) $-3.2 \times 10^{-15} \text{ J}$
 C) $+1.2 \times 10^{-15} \text{ J}$
 D) $-5.1 \times 10^{-15} \text{ J}$
 E) $-1.8 \times 10^{-15} \text{ J}$
2. Two point charges are located at two of the vertices of a right triangle, as shown in the figure. If a third charge $-q$ is brought from infinity and placed at the third vertex, what will its electric potential energy be? Use the following values: $a = 0.35 \text{ m}$; $b = 0.65 \text{ m}$, and $q = 3.0 \times 10^{-6} \text{ C}$.

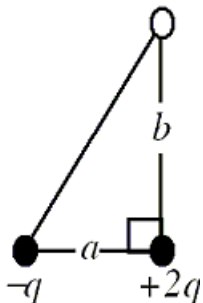

- A) -1.7 J
 B) -0.14 J
 C) -0.028 J
 D) $+0.85 \text{ J}$
 E) $+1.7 \text{ J}$

Use the following to answer question 3:

Two point charges are held at the corners of a rectangle as shown in the figure. The lengths of sides of the rectangle are 0.050 m and 0.150 m. Assume that the electric potential is defined to be zero at infinity.



3. What is the electric potential energy of a $+3.0 \mu\text{C}$ charge placed at corner **A**?
- A) 0.10 J
 - B) 0.18 J
 - C) 2.3 J
 - D) 3.6 J
 - E) zero joules

Use the following to answer questions 4-5:

Four point charges are individually brought from infinity and placed at the corners of a square as shown in the figure. Each charge has the identical value $+Q$. The length of the diagonal of the square is $2a$.

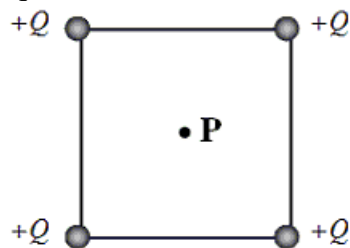

4. The first two charges are brought from infinity and placed at adjacent corners. What is the electric potential energy of these two charges?

A) $\frac{kQ^2}{a\sqrt{2}}$

B) $\frac{2kQ}{a}$

C) $\frac{kQ}{a\sqrt{2}}$

D) $\frac{kQ^2}{2a}$

E) $\frac{kQ^2}{4a}$

5. What is the magnitude of the electric field at **P**, the center of the square?

A) kQ/a^2

B) $2kQ/a^2$

C) $4kQ/a^2$

D) $kQ/4a^2$

E) zero V/m

Use the following to answer question 6:

P and **Q** are points within a uniform electric field that are separated by a distance of 0.2 m as shown. The potential difference between **P** and **Q** is 75 V.

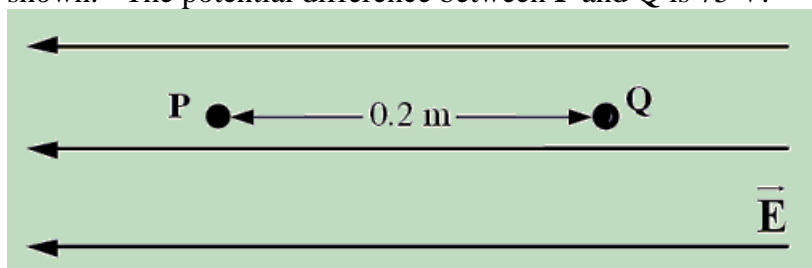

6. How much work is required to move a $+150 \mu\text{C}$ point charge from **P** to **Q**?

A) 0.023 J

B) 0.056 J

C) 75 J

D) 140 J

E) 2800 J

Use the following to answer question 7:

Two charges of opposite sign and equal magnitude $Q = 0.82 \text{ C}$ are held 2.0 m apart as shown in the figure.

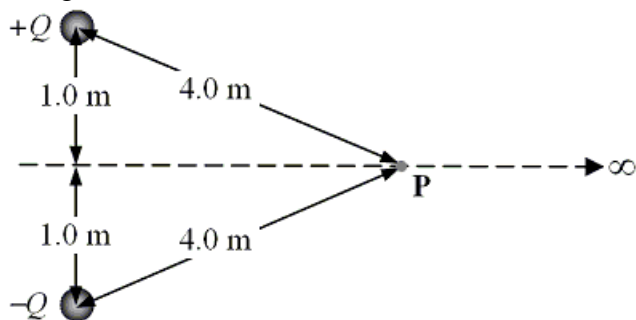

7. Determine the electric potential at the point P .
 - A) $1.1 \times 10^9 \text{ V}$
 - B) $2.2 \times 10^9 \text{ V}$
 - C) $4.5 \times 10^9 \text{ V}$
 - D) $9.0 \times 10^9 \text{ V}$
 - E) zero volts

8. Which one of the following statements concerning electrostatic situations is false?
 - A) \mathbf{E} is zero everywhere inside a conductor.
 - B) Equipotential surfaces are always perpendicular to \mathbf{E} .
 - C) Zero work is needed to move a charge along an equipotential surface.
 - D) If V is constant throughout a *region of space*, then E must be zero in that region.
 - E) No force component acts along the path of a charge as it is moved along an equipotential surface.

9. The magnitude of the charge on the plates of an *isolated* parallel plate capacitor is doubled. Which one of the following statements is true concerning the capacitance of this parallel-plate system?
 - A) The capacitance is decreased to one half of its original value.
 - B) The capacitance is increased to twice its original value.
 - C) The capacitance remains unchanged.
 - D) The capacitance depends on the electric field between the plates.
 - E) The capacitance depends on the potential difference across the plates.

10. A parallel plate capacitor is fully charged at a potential V . A dielectric with constant $\kappa = 4$ is inserted between the plates of the capacitor while the potential difference between the plates remains constant. Which one of the following statements is false concerning this situation?
- A) The energy density remains unchanged.
 - B) The capacitance increases by a factor of four.
 - C) The stored energy increases by a factor of four.
 - D) The charge on the capacitor increases by a factor of four.
 - E) The electric field between the plates increases by a factor of four.
11. A physics student performed an experiment in which the potential difference V between the ends of a long straight wire was varied. The current I in the wire was measured at each value of the potential difference with an ammeter and the results of the experiment are shown in the table.

<i>Trial</i>	<i>V (volts)</i>	<i>I (amperes)</i>
1	5.0	0.25
2	10.0	0.50
3	15.0	0.75
4	20.0	1.00
5	25.0	1.50
6	30.0	1.65
7	35.0	1.55
8	40.0	1.53

- Which one of the following statements is the *best* conclusion based on the data?
- A) The resistance of the wire is 20Ω .
 - B) The wire does not obey Ohm's law.
 - C) The current in the wire is directly proportional to the applied potential difference.
 - D) The wire obeys Ohm's law over the range of potential differences between 5 and 30 V.
 - E) The wire obeys Ohm's law over the range of potential differences between 5 and 20 V.
12. Determine the length of a copper wire that has a resistance of 0.172Ω and cross-sectional area of $7.85 \times 10^{-5} \text{ m}^2$. The resistivity of copper is $1.72 \times 10^{-8} \Omega \cdot \text{m}$.
- A) 873 m
 - B) 250 m
 - C) 78.5 m
 - D) 785 m
 - E) 6570 m

13. A 4-A current is maintained in a simple circuit with a total resistance of $2\ \Omega$. How much energy is delivered in forty five seconds?
 A) 1440 J
 B) 96 J
 C) 360 J
 D) 720 J
 E) 240 J
14. A 75-W and 50-W incandescent light bulbs are designed for use with the same voltage. What is the ratio of the resistance of the 75-W bulb to the resistance of the 50-W bulb?
 A) 1.5
 B) 0.67
 C) 2.3
 D) 0.44
 E) 3.0
15. A $220\text{-}\Omega$ resistor is connected across an ac voltage source $V = (150\text{ V}) \sin [2\pi(60\text{ Hz})t]$. What is the average power delivered to this circuit?
 A) 51 W
 B) 110 W
 C) 280 W
 D) 320 W
 E) 550 W
16. Some light bulbs are connected in parallel to a 120 V source as shown in the figure. Each bulb dissipates an average power of 60 W. The circuit has a fuse **F** that burns out when the current in the circuit exceeds 9 A. Determine the largest number of bulbs, which can be used in this circuit without burning out the fuse.



- A) 9
 B) 17
 C) 25
 D) 34
 E) 36

17. What is the total power dissipated in the two resistors in the circuit shown?

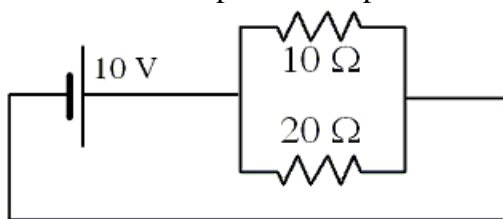

- A) 10 W
- B) 15 W
- C) 33 W
- D) 67 W
- E) 670 W

Use the following to answer question 18:

Three resistors are connected as shown in the figure. The potential difference between points **A** and **B** is 26 V.

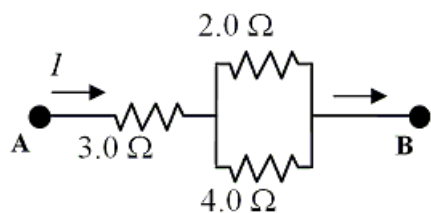

18. What is the equivalent resistance between the points **A** and **B**?

- A) 3.8 Ω
- B) 4.3 Ω
- C) 5.1 Ω
- D) 6.8 Ω
- E) 9.0 Ω

19. Three resistors and two batteries are connected as shown in the circuit diagram. What is the magnitude of the current through the 12-V battery?

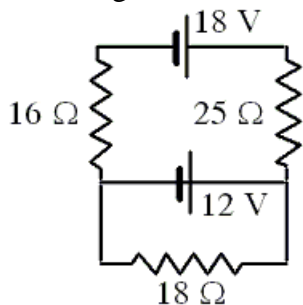

- A) 0.15 A
- B) 0.82 A
- C) 0.30 A
- D) 0.67 A
- E) 0.52 A

Use the following to answer question 20:

The figure shows a simple RC circuit consisting of a 100.0-V battery in series with a 10.0- μF capacitor and a resistor. Initially, the switch S is open and the capacitor is uncharged. Two seconds after the switch is closed, the voltage across the resistor is 37 V.

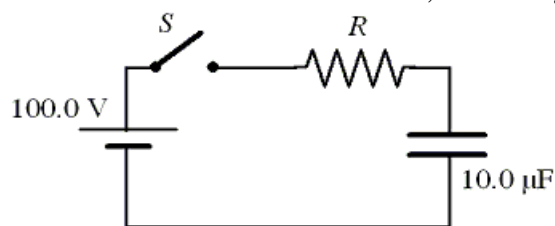

20. How much charge is on the capacitor 2.0 s after the switch is closed?
- A) 1.1×10^{-3} C
 - B) 2.9×10^{-3} C
 - C) 3.7×10^{-4} C
 - D) 5.2×10^{-4} C
 - E) 6.6×10^{-4} C

21. An electron traveling due south enters a region that contains both a magnetic field and an electric field.

The electric field lines point due west. It is observed that the electron continues to travel in a straight line due south. In which direction must the magnetic field lines point?

- A) up
- B) down
- C) east
- D) west
- E) south

22. An proton travels through a region of space with no acceleration. Which one of the following statements is the best conclusion?

- A) Both \mathbf{E} and \mathbf{B} must be zero in that region.
- B) \mathbf{E} must be zero, but \mathbf{B} might be non-zero in that region.
- C) \mathbf{E} and \mathbf{B} might both be non-zero, but they must be mutually perpendicular.
- D) \mathbf{B} must be zero, but \mathbf{E} might be non-zero in that region.
- E) \mathbf{E} and \mathbf{B} might both be non-zero, but they must point in opposite directions.

23. An electron traveling horizontally enters a region where a uniform magnetic field is directed into the plane of the paper as shown. Which one of the following phrases most accurately describes the motion of the electron once it has entered the field?

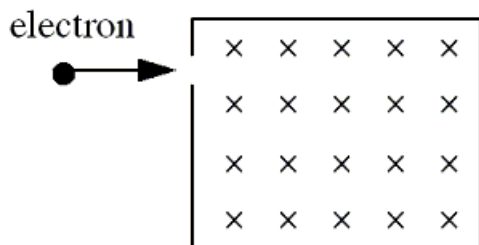

- A) upward and parabolic
- B) upward and circular
- C) downward and circular
- D) upward, along a straight line
- E) downward and parabolic

24. Two charged particles of equal mass are traveling in circular orbits in a region of uniform, constant magnetic field as shown. The particles are observed to move in circular paths of radii R_1 and R_2 with speeds v_1 and v_2 , respectively.

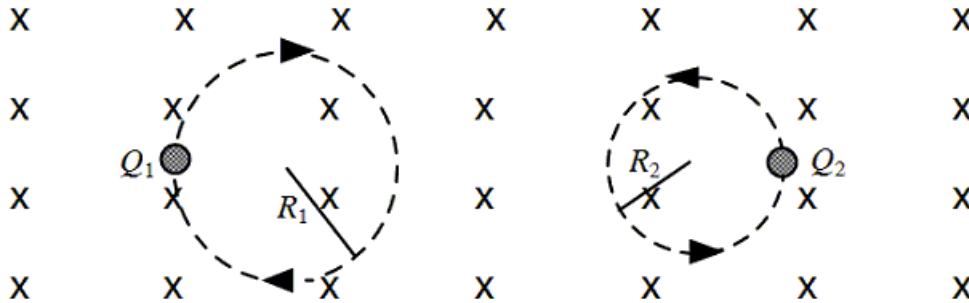

As the figure shows, the path of particle 2 has a smaller radius than that of particle 1. Which one of the following statements about this system is false?

- A) $|v_1/Q_1| < |v_2/Q_2|$
- B) Particle 2 carries a positive charge.
- C) Particle 1 carries a negative charge.
- D) Neither particle gains energy from the magnetic field.
- E) The particle velocities have no components parallel to the magnetic field.

Use the following to answer question 25:

A beam consisting of five types of ions labeled **A**, **B**, **C**, **D**, and **E** enters a region that contains a uniform magnetic field as shown in the figure below. The field is perpendicular to the plane of the paper, but its precise direction is not given. All ions in the beam travel with the same speed. The table below gives the masses and charges of the ions. **Note:** 1 mass unit = 1.67×10^{-27} kg and $e = 1.6 \times 10^{-19}$ C

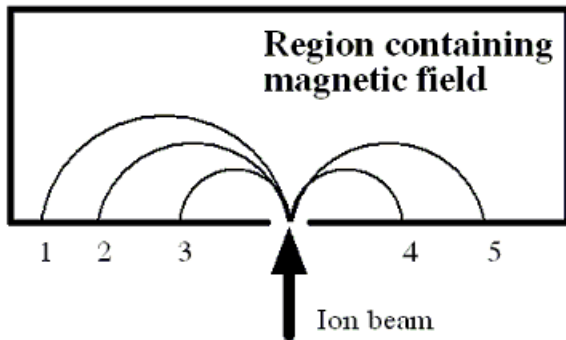

<u>Ion</u>	<u>Mass</u>	<u>Charge</u>
A	2 units	$+e$
B	4 units	$+e$
C	6 units	$+e$
D	2 units	$-e$
E	4 units	$-e$

25. Which ion falls at position 2?
- A) **A**
 - B) **B**
 - C) **C**
 - D) **D**
 - E) **E**

Answer Key

1. D
2. B
3. B
4. A
5. E
6. B
7. E
8. E
9. C
10. E
11. E
12. D
13. A
14. B
15. A
16. B
17. B
18. B
19. E
20. C
21. B
22. C
23. C
24. A
25. B